

## LVM-110

### Voltage Output LVDT/RVDT OEM Signal Conditioner

#### SPECIFICATIONS

- **Low cost OEM signal conditioner**
- **Very compact, open PC board design**
- **Multiple unipolar and bipolar output options**
- **DIP switch selectable gain and excitation**
- **2.5, 5, 8 and 10kHz excitation frequencies**
- **Zero and span adjustment potentiometers**
- **Master/slave capability**
- **Card-edge or barrier strip connections**
- **Works with very low input impedance LVDTs and RVDTs**

#### FEATURES

- Low cost/high performance
- 3-pole Butterworth filter
- DIP switch selectable gain, output and LVDT excitation frequency
- 20-turn zero suppression & span potentiometers

#### APPLICATIONS

- Position feedback systems
- High density dimensional gaging
- Space restrictive installations
- Testing systems
- Integration into OEM machines

The **LVM-110** is a full-featured LVDT/RVDT signal conditioner that offers excellent performance on a budget. Operating on either a  $\pm 12$  or  $\pm 15$ VDC supply voltage, the LVM-110 delivers a full range of selectable unipolar and bipolar, low noise DC voltage outputs.

Designed to be compatible with most LVDT and RVDT transducers, the LVM-110 will operate with 5 and 6 electrical connection devices. This versatility is due to the wide variety of selectable excitation frequencies, and a generous excitation drive current of 20mA, allowing operation with transducer input impedances as low as 150 Ohms. The master/slave function (DIP switch selectable) allows synchronization of multiple conditioners to prevent beat frequencies and cross talk between transducers. The need for phase correction adjustment is eliminated thanks to demodulation synchronized to the sum of the LVDT/RVDT outputs.

The LVM-110 is designed for easy installation, plugged into a backplane-type connector, or with individual wires connected to the screw terminal barrier strip. Measuring less than 2.5x2.5 inches, it can be mounted or stacked using the permanently attached threaded standoffs, or card-edge guides. All selectable operating parameters are easily accessed via two DIP switches, simplifying the gain, frequency and output setup procedure.

## LVM-110

Voltage Output, LVDT/RVDT OEM Signal Conditioner

### PERFORMANCE SPECIFICATIONS

ELECTRICAL SPECIFICATIONS	
Supply voltage	$\pm 12\text{VDC}$ or $\pm 15\text{VDC}$ , $\pm 10\%$ (Note: $\pm 15\text{VDC}$ required for $\pm 10\text{VDC}$ output)
Supply current	$\pm 50\text{mA}$ maximum
Output voltage ranges	$\pm 5\text{VDC}$ , $\pm 10\text{VDC}$ , 0 to $+5\text{VDC}$ , 0 to $+10\text{VDC}$ (DIP switch selectable)
Temperature coefficient of output	$\pm 0.02\%$ of FSO per $^{\circ}\text{F}$ [ $\pm 0.036\%$ of FSO per $^{\circ}\text{C}$ ] over operating temperature range
Output current	5mA maximum
Output noise and ripple	15mV RMS maximum
Output impedance	1 $\Omega$ maximum
Frequency response	250Hz @ -3 dB (3-pole Butterworth filter)
Non-linearity	$\pm 0.05\%$ of FSO maximum
Stability	$\pm 0.05\%$ of FSO maximum (after 15 minute warm-up)
Zero suppression	$\pm 6\text{VDC}$ total
Transducer excitation	
Voltage	3VRMS $\pm 10\%$ , sine wave
Current	20mA RMS maximum
Frequency	2.5, 5, 8 or 10KHz (DIP switch selectable)
Transducer requirements	
Transducer type	LVDT or RVDT with 5 or 6 electrical connections
LVDT/RVDT input impedance	150 $\Omega$ minimum
LVDT/RVDT output range	0.1 to 5.6 VRMS for $\pm 10\text{VDC}$ signal conditioner output

ENVIRONMENTAL AND MECHANICAL SPECIFICATIONS	
Operating temperature range	30 $^{\circ}\text{F}$ to $+130^{\circ}\text{F}$ [ $-1^{\circ}\text{C}$ to $55^{\circ}\text{C}$ ]
Storage temperature range	$-40^{\circ}\text{F}$ to $+257^{\circ}\text{F}$ [ $-40^{\circ}\text{C}$ to $125^{\circ}\text{C}$ ]
Zero and gain adjustments	20-turn potentiometers
Electrical connections	PC board edge (to backplane-type connector) or barrier terminal strip (accepts AWG 14 to 30 wire sizes)
Mounting	Use the attached threaded standoffs or card-edge guides

#### Notes:

All values are nominal unless otherwise noted

FSO (Full Scale Output) is the largest absolute value of the outputs measured at the range ends

### WIRING SCHEMATIC

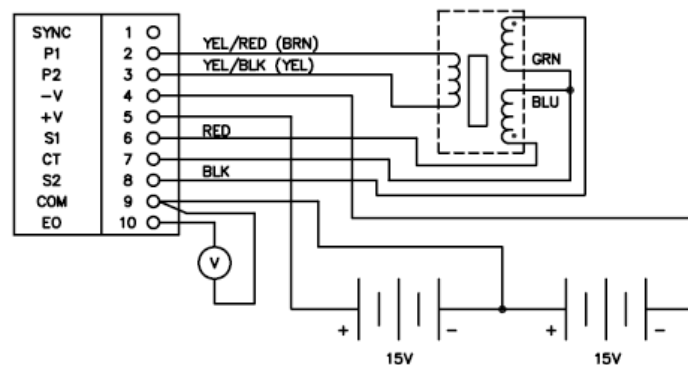

## LVM-110

Voltage Output, LVDT/RVDT OEM Signal Conditioner

## DIMENSIONS

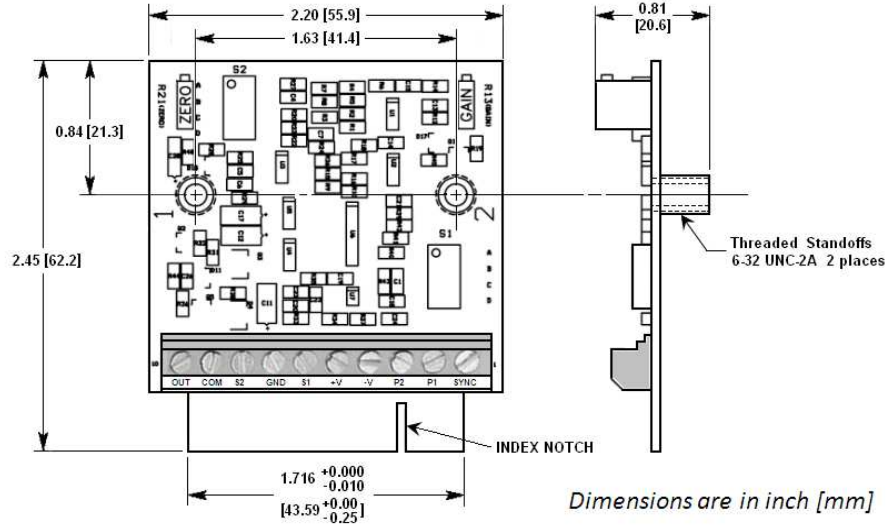

## ORDERING INFORMATION

Description	Model	Part Number
LVDT/RVDT Voltage Output, OEM Signal Conditioner	LVM-110	04171776-000
Dual rail DC power supply ( $\pm 15\text{VDC}$ )	PSD 40-15	02291339-000
Mating Connector ( <i>sold separately</i> )	CINCH 5010A-20 PCB EDGE 1	62105012-000
Cable to connect HCA/HCI/GCA/R36AS to LVM-110 (1)	PTO6A-10-6S to Stripped & Tinned	04290417-000
Extension cable to connect LBB (option -001) to LVM-110 (1)	PTO6A-10-6S to Stripped & Tinned	04290582-000

(1) All cables are shielded, 10 foot long, and rated 80°C [176°F]. Consult factory for other lengths.