

A perfect solution for both OEM and single-piece user, this string pot provides an economically priced CANopen sensor for 80-inch and 120-inch stroke range applications. This sensor is constructed with a rugged polycarbonate enclosure, a stainless steel mounting bracket and universally accepted M12 connector for operation in both outdoor or factory dry environments. For the OEM, customized options are available.

Ordering Information:

w/o terminating resistor

	Part No. SGH-80-4 80-inch stroke range, no terminating resistor, 5-pin M12 mating plug, mounting bracket included	Part No. SGH-120-4 120-inch stroke range, no terminating resistor, 5-pin M12 mating plug, mounting bracket included
--	---	---

w/ terminating resistor

	Part No. SGH-80-4-TR 80-inch stroke range, with terminating resistor, 5-pin M12 mating plug, mounting bracket.	Part No. SGH-120-4-TR 120-inch stroke range, with terminating resistor, 5-pin M12 mating plug, mounting bracket.
--	--	--

	Optional Cordset for short-run connections, a convenient optional 16-ft. cordset with a 5-pin M12 connector.	Part No. 9036810-0030
--	--	---------------------------------

	Field Installable Connector While every SGJ ships with a field installable 5-pin M12 mating plug, additional connectors are available.	Part No. 9036810-0032
--	--	---------------------------------

SGH

Cable Actuated Sensor Industrial • CANOpen

Two Available Stroke Ranges: 0-80 in & 0-120 in.

Rugged Polycarbonate Enclosure • Simple Installation

Compact Design • Built for IP67 environments

IN STOCK FOR QUICK DELIVERY!

Specifications

Stroke Range Options	80 in. (2032 mm), 120 in. (3048 mm)
Accuracy	.5% FS.
Repeatability	.05% FS.
Resolution	12-bit
Input Voltage	10-36 VDC
Input Current	100 mA, max.
Measuring Cable	.019-inch dia. nylon-coated stainless steel
Measuring Cable Tension, 80-inch	14 oz. (3.9 N) ±30%
Measuring Cable Tension, 120-inch	9 oz. (2.5 N) ±30%
Maximum Acceleration	10 g
Sensor	plastic-hybrid precision potentiometer
Cycle Life	≥ 250,000
Electrical Connection	M12 connector (mating plug included)
Enclosure	glass-filled polycarbonate
Environmental	IP 67
Operating Temperature	-40° to 185° F (-40° to 85°C)
Weight, 80-inch (not including bracket)	.6 lbs (272 g)
Weight, 120-inch (not including bracket)	1 lb. (454 g)

CANopen Specifications

Communication Profile	CiA 301 V 4.0.2, CANopen Slave
Device Type	CiA 406 V3.2, Encoder
Vendor ID	Company x0002E0, Dept x00
Node ID	1-127 (Adjustable via dipswitch or LSS, default set to 1)
Baud Rate Options	125K (default), 250K, 500K, 1M
Data Rate	50ms (default)
Error Control	Heartbeat, Emergency Message
PDO	2 TxPDO, 0 RxPDO, no linking, static mapping
PDO Modes	Event / Time triggered, Synch / Async
SDO	1 server, 0 client
Position Data	Object Dictionary 6004
Cam Switches	Not Supported
Termination Resistor	See Ordering Information

Electrical Connection:



signal	pin	pin-colorcode
n/c	1	1 - brown
10...36 Vdc	2	2 - white
common	3	3 - blue
CAN high	4	4 - black
CAN low	5	5 - green/yellow

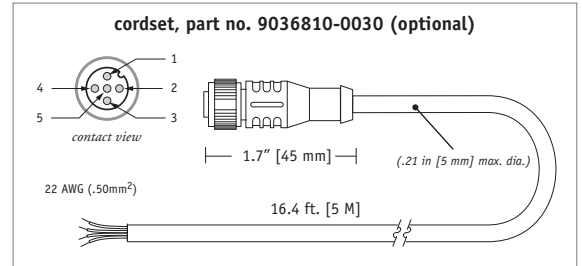
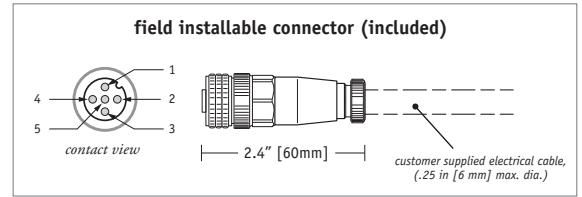

Position Data Overview:

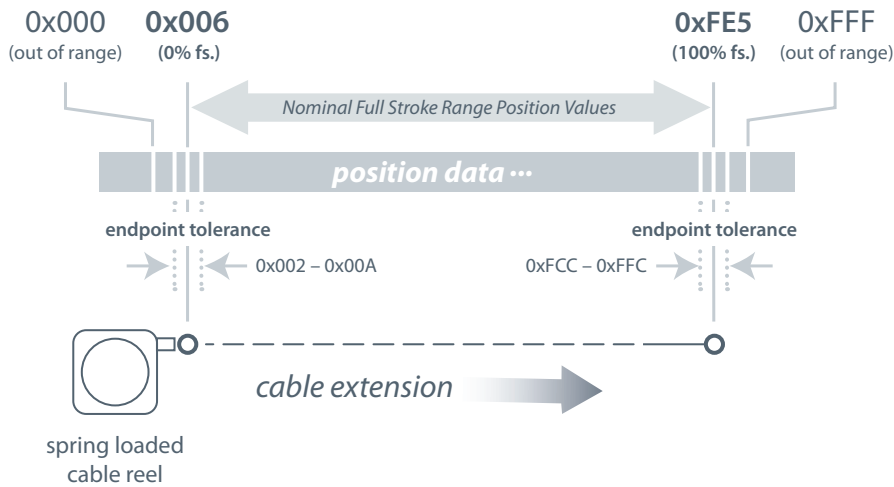

Internal Controller Board

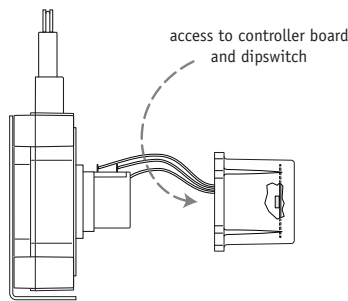
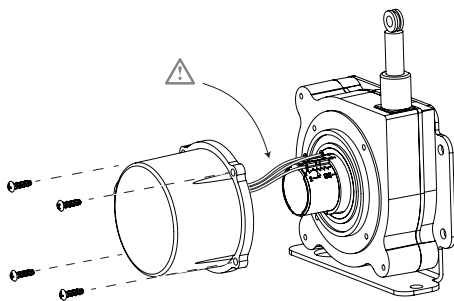

Status LED - Indicates Operating Condition of the Potentiometer

green	red
on	flash
off	flash
on	off
flash	off
flash	on

emergency message (high)
buffer (high)
normal operating range
buffer (low)
emergency message (low)

LSS, Baud Rate and Node ID settings:

LSS, Baud Rate and Node ID settings are set via dip switch found on the internal controller board. To gain access to the controller board, remove the 4 cover attaching screws and carefully separate the sensor cover from the main body. Be careful not to damage the small gage wires that connect the potentiometer to the controller board mounted directly to the rear cover.

Follow the instructions below for desired settings and reinstall sensor cover.

Settings (cont.):

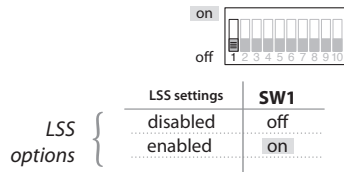

LSS Settings:

IF DIP Switch 1 is set to “on” position, then LSS will be functional and uses the contents of EEPROM including Node ID and Baud Rate. If DIP Switch 1 is set to “off” position, then DIP switches will override information in EEPROM including the Node ID and Baud Rate.

BAUD Rate:

If DIP Switch 1 is set to “off” then BAUD rate is set via DIP switch 2 and 3 as shown :

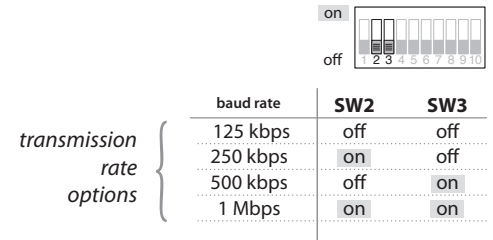

node ID Dec. Hex	SW4	SW5	SW6	SW7	SW8	SW9	SW10
	(2 ⁰)	(2 ¹)	(2 ²)	(2 ³)	(2 ⁴)	(2 ⁵)	(2 ⁶)
1 0x01	on	off	off	off	off	off	off
2 0x02	off	on	off	off	off	off	off
3 0x03	on	on	off	off	off	off	off
...
126 0x7E	off	on	on	on	on	on	on
127 0x7F	on	on	on	on	on	on	on

node ID options 1-127 (0x01-0x7F)

Node ID:

If DIP Switch 1 is set to “off” then the Node ID is set via DIP switches 4 – 10 as shown below. The DIP switch settings are binary starting with switch number 4 (=2⁰) and ending with switch number 10 (=2⁶).

The Node ID is equal to the binary setting.

Manufacturer Objects:

Index	Sub-Index	Name	Default	Comment
2000		Raw Position Value		This is the averaged, non-scaled value from the encoder.
2001		Emergency Buffer Distance	0.1	Emergency Message is sent when the output of the sensing potentiometer is outside it’s calibrated range by more than .1% of the sensors full measurement range (Emergency Buffer). This allows for non-repeatability of sensor and customers application. This object allows user ability to change buffer size along with transmission of Emergency Message, Manufacturer specific bit in error register set, and error added to error list.

Device Profile Area:

Index	Sub-Index	Name	Default	Comment
6000		Operating Parameters	0X0000	
6004		Position Value	0	Counts proportional to measuring cable extension. Nominal values are 0x006 with cable fully retracted and 0xFE5 with cable fully extended. Format of data in CAN message is little endian – least significant byte pair first. Therefore 0x008 would be shown as “08 00” and 0xFE5 would be shown as “E5 0F”
6400		Area State Register		SubNumber= 2 (indicates underflow or overflow per CiA406)
	0	Highest Subindex	0x01	
	1	Work Area State Channel 1	0	

Device Profile Area (cont.):

6401		Work Area Low Limit		The averaged, non-scaled (raw) encoder data below which the encoder is out of range.
	0	Highest Subindex	0x01	
	1	Work Area Low Limit Channel1	0x024	
6402		Work Area High Limit		The averaged, non-scaled (raw) encoder data above which the encoder is out of range.
	0	Highest Subindex	0x01	
	1	Work Area High Limit Channel 1	0xF4E	
6500		Operating Status	0x0000	
6501		Measuring Step	1	Position Measuring Step. Can be set by user to convert Position Value (Object 6004) to measurement units (inches, mm). Default is set to 1.

Communication Area Profile:

Index	Sub-Index	Name	Default	Comment
1000		Device Type	0X00080196	Device Profile 406
1001		Error Register	0	Manufacturer Specific Error bit 7 is set when sensor is outside of calibrated range and cleared when back in range.
1003		Pre-Defined Error Field		SubNumber= 9 (lists last eight Emergency Messages)
	0	Number of Errors	0	
	1	Standard Error Field 1		
	2	Standard Error Field 2		
	3	Standard Error Field 3		
	4	Standard Error Field 4		
	5	Standard Error Field 5		
	6	Standard Error Field 6		
	7	Standard Error Field 7		
	8	Standard Error Field 8		
1005		SYNC COB-ID	0x80	
1010		Store Parameters		SubNumber=2
1010	0	Highest Subindex	0x01	Only "Save All Parameters" feature supported
	1	Save All Parameters		Write "save" or "evsa" to save parameters to EEPROM. They are automatically loaded on power up/reset. Saves the value of all R/W object dictionary entries.
1014		Emergency COB-ID	\$NodeID + 0x80	COB-ID Emergency Message
1015		Emergency Inhibit Time	0	Multiple of 100us. Minimum time between transmissions of emergency messages.
1017		Producer Heartbeat Time	0	Multiples of 1ms. Time between transmission of heartbeat messages. 0 = disabled

Communication Area Profile (cont.):

1018		Identity Object		
	0	Number of Entries	4	
	1	Vendor Id	0x2E0	
	2	Product Code	269 (decimal)	Celesco Reference # 604269
	3	Revision Number	1	
	4	Serial Number	0x00000000	
1800		Tx PDO Comm. Parameter		PDO1
	0	Number of Entries	5	
	1	COB-ID	\$NodeID + 0x108	COB-ID used by PDO1
	2	Transmission Type	254	PDO1 Tx Type: 0 = on Sync Message. 254 = Asynchronous Tx
	3	Inhibit Time	0	Multiple of 100us. Minimum time between transmissions of the PDO
	5	Event Timer	0x32	If non-zero then transmits the PDO periodically. This value is a multiple of 1ms.
1801		Tx PDO Comm. Parameter		PDO2
	0	Number of Entries	5	
	1	COB-ID	\$NodeID + 0x280	COB-ID used by PDO2
	2	Transmission Type	0	PDO2 Tx Type: 0 = on Sync Message. 254 = Asynchronous Tx
	3	Inhibit Time	0	Multiple of 100us. Minimum time between transmissions of the PDO
	5	Event Timer	0	If non-zero then transmits the PDO periodically. This value is a multiple of 1ms.
1A00		Tx PDO Mapping Parameter		Subnumber = 2
	0	Number of Entries	1	
	1	PDO Mapping Entry	0x60040020	Mapping Parameter
1A01		Tx PDO Mapping Parameter		Subnumber = 2
	0	Number of Entries	1	
	1	PDO Mapping Entry	0x60040020	Mapping Parameter

80-inch SGH-80-4 w/ Mounting Bracket:

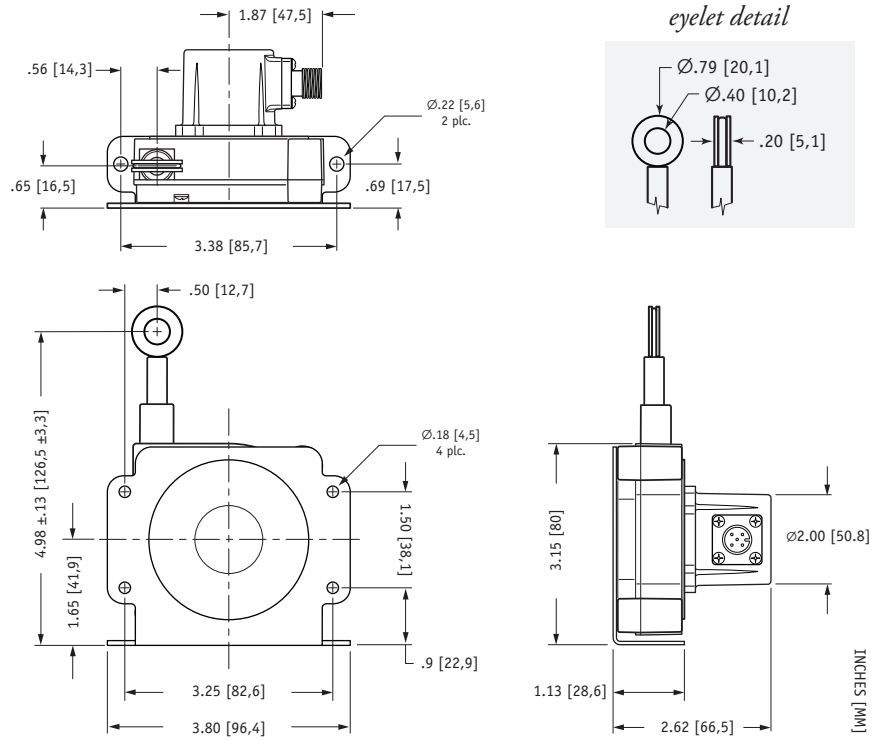

120-inch SGH-120-4 w/ Mounting Bracket:

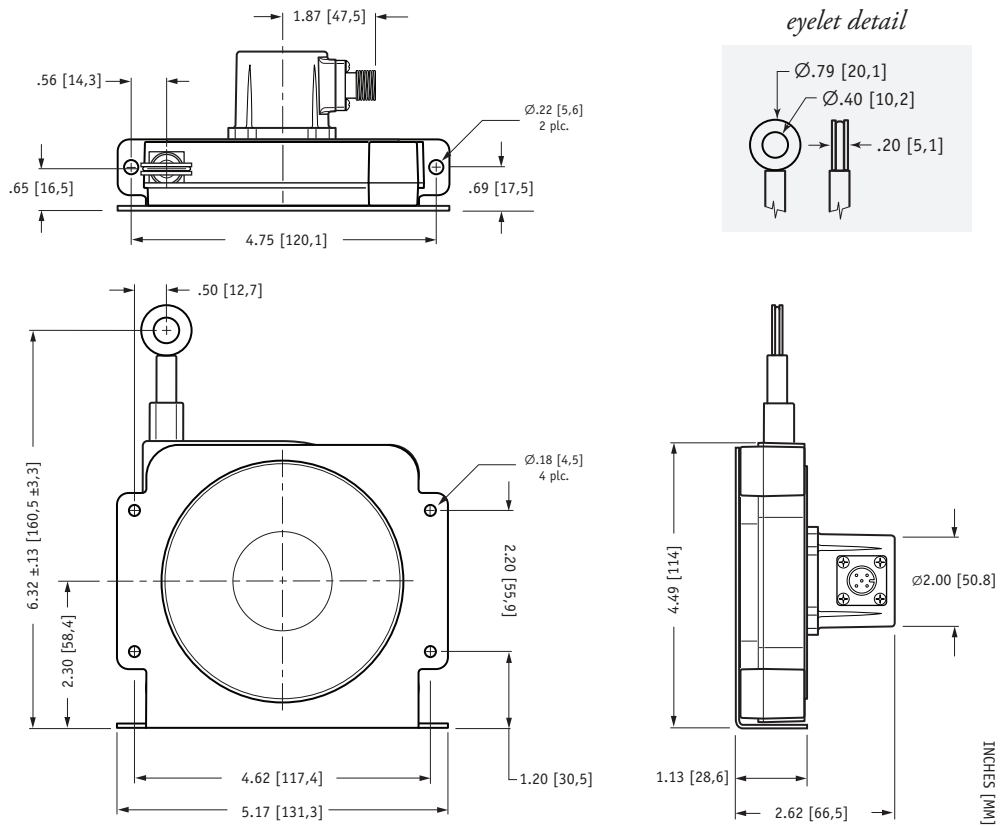

Mounting Options:

Changing Measuring Cable Exit and Electrical Connector Direction:

For the ultimate in flexibility, the measuring cable exit direction and the direction of the electrical connector can be rotated around in 90° increments to accommodate just about any installation requirement.

To change measuring cable exit direction, simply remove the 4 mounting bracket screws, rotate the bracket to desired position and replace the screws.

To change the direction of the electrical connector, remove the 4 sensor cover screws and carefully remove the sensor cover just far enough to separate the cover from the main body. Be careful of the three small gage wires that attach the internal controller board to the potentiometer.

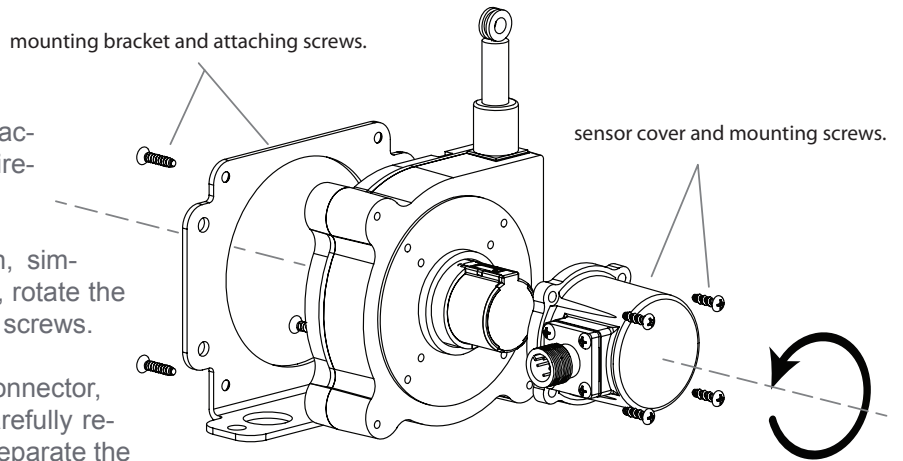

Mounting Option Mounting Dimensions • 80-inch (SGH-80-4):

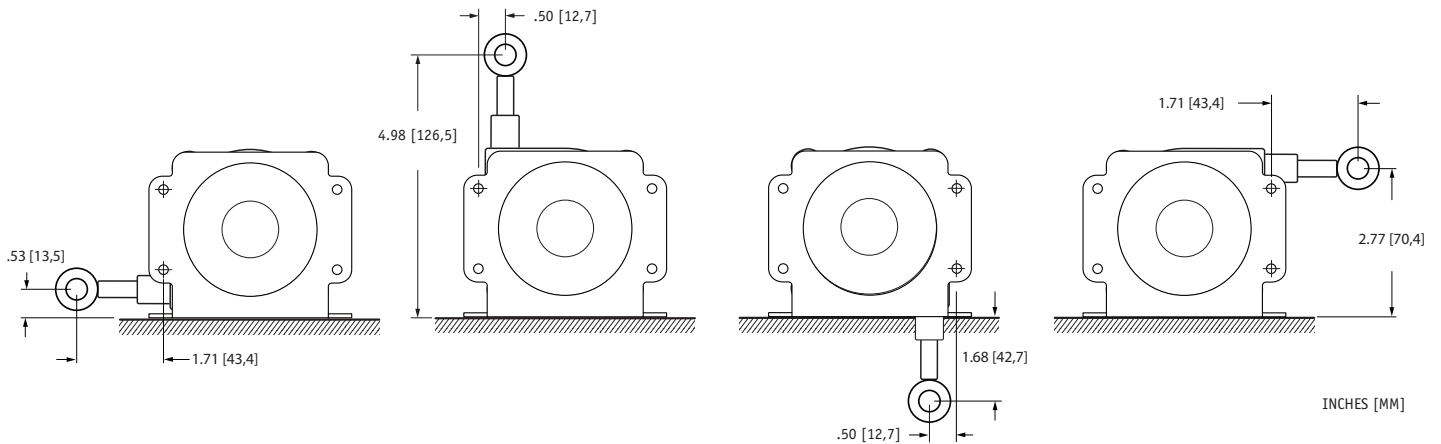

Mounting Option Mounting Option Dimensions • 120-inch (SGH-120-4):

