



PT9CN (Extended Range)

Cable Actuated Sensor

Heavy Industrial • J1939 CANbus

Linear Position/Velocity to 1700 inches (4300 cm)

Stroke Range Options: 0-600 to 0-1700 inches

IP68 • NEMA 6 Protection

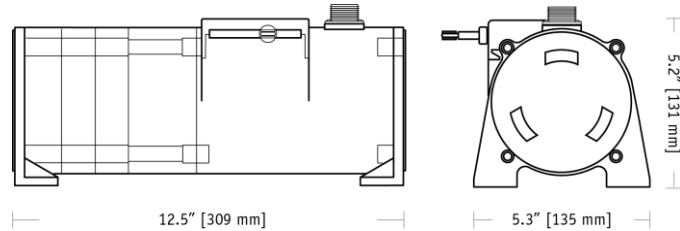

The PT9CN communicates linear position feedback via the CANbus SAE J1939 interface. The PT9CN has been designed for factory and harsh environment applications requiring full stroke ranges up to 1700".

As a member of our innovative family of NEMA 4 rated cable-extension transducers, the PT9CN installs in minutes by simply mounting its body to a fixed surface and attaching its cable to the movable object. Perfect parallel alignment not required.

Output Signal

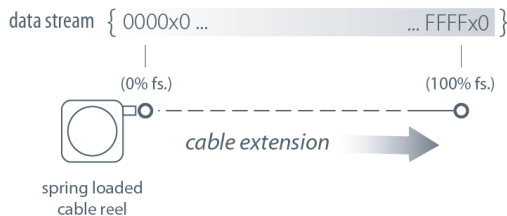

General

Full Stroke Range	0-600 to 0-1700 inches
Electrical Interface	CANbus SAE J1939
Protocol	Proprietary B
Accuracy	± 0.10% full stroke
Repeatability	± 0.02% full stroke
Resolution	± 0.003% full stroke
Measuring Cable Options	nylon-coated stainless steel
Enclosure Material	powder-painted aluminum or stainless steel
Sensor	plastic-hybrid precision potentiometer
Potentiometer Cycle Life	≥ 250,000 cycles
Maximum Retraction	see ordering information
Acceleration	
Maximum Velocity	see ordering information
Weight, Aluminum (Stainless Steel) Enclosure	14 lbs. (28 lbs.), max.

Electrical

Input Voltage	7 - 18 VDC
Input Current	60 mA max.
Address Setting (Node ID)	0..63 set via DIP switches
Baud Rate	125K, 250K or 500K set via DIP switches
Update Rate	10 ms. (20 ms. available, contact factory)

Environmental

Enclosure	NEMA 4/4X/6, IP 67
Operating Temperature	-40° to 200°F (-40° to 90°C)
Vibration	up to 10 g to 2000 Hz maximum

I/O Format and Settings

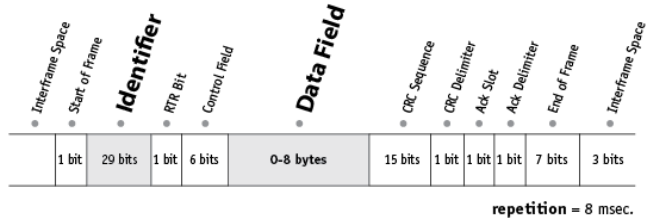

• Identifier

	Message Priority				Future Use				J1939 Reference Proprietary B								Data Field Type*								Not Used		Node ID**							
Example –	1	0	0	0	0	0	1	1	1	1	1	1	1	1	1	1	1	1	0	1	0	1	0	0	1	1	0	0	1	1	1	1	1	1
Identifier Bit No. –	28	27	26	25	24	23	22	21	20	19	18	17	16	15	14	13	12	11	10	9	8	7	6	5	4	3	2	1	0					
Hex Value –	0				F				F				5				3				3		F											

*Sensor field data can be factory set to customer specific value. **Customer defined, set via Dips 1-6. Bit values shown for example only, see Address Setting below.

• Data Field

B₀ = LSB current % of measurement range byte
 B₁ = MSB current % of measurement range byte
 B₂ = LSB current measurement count byte
 B₃ = MSB current measurement count byte

B₄ = error flag
 B₅ = error flag
 B₆ = LSB velocity data byte
 B₇ = MSB velocity data byte

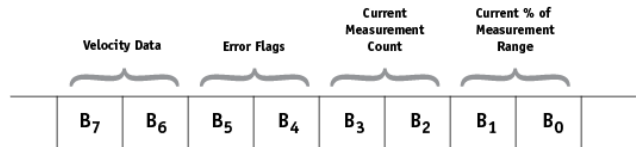

B ₇	B ₆	B ₅	B ₄	B ₃	B ₂	B ₁	B ₀
----------------	----------------	----------------	----------------	----------------	----------------	----------------	----------------

Current Measurement Count

The Current Measurement Count (CMC) is the output data that indicates the present position of the measuring cable. The CMC is a 16-bit value that occupies bytes B₂ and B₃ of the data field. B₂ is the LSB (least significant byte) and B₃ is the MSB (most significant byte).

The CMC starts at 0x0000 with the measuring cable fully retracted and continues upward to the end of the stroke range stopping at 0xFFFF. This holds true for all ranges.

Converting CMC to Linear Measurement

To convert the current measurement count to inches or millimeters, simply divide the count by 65,535 (total counts over the range) and then multiply that value by the full stroke range:

$$\left(\frac{\text{current measurement count}}{65,535} \right) \times \text{full stroke range}$$

Sample Conversion:

If the full stroke range is 30 inches and the current position is 0x0FF2 (4082 Decimal) then,

$$\left(\frac{4082}{65,535} \right) \times 30.00 \text{ inches} = 1.87 \text{ inches}$$

If the full stroke range is 625 mm and the current position is 0x0FF2 (4082 Decimal) then,

$$\left(\frac{4082}{65,535} \right) \times 625 \text{ mm} = 39 \text{ mm}$$

B ₇	B ₆	B ₅	B ₄	B ₃	B ₂	B ₁	B ₀
----------------	----------------	----------------	----------------	----------------	----------------	----------------	----------------

Current % of Measurement Range

The Current % of Measurement Range is a 2-byte value that expresses the current linear position as a percentage of the entire full stroke range. Resolution is .1 % of the full stroke measurement range.

This value starts at 0x0000 at the beginning of the stroke and ends at 0x03E8.

Example:

Hex	Decimal	Percent
0000	0000	0.0%
0001	0001	0.1%
0002	0002	0.2%
...
03E8	1000	100.0%

B ₇	B ₆	B ₅	B ₄	B ₃	B ₂	B ₁	B ₀
----------------	----------------	----------------	----------------	----------------	----------------	----------------	----------------

Error Flags

0x55 (yellow LED on controller board) indicates that the sensor has begun to travel beyond the calibrated range of the internal position potentiometer.

0xAA (red LED on controller board) indicates that the sensor has moved well beyond the calibrated range of the internal position potentiometer.

If either error flag occurs within the full stroke range of the sensor, the unit should be returned to the factory for repair and recalibration.

B ₇	B ₆	B ₅	B ₄	B ₃	B ₂	B ₁	B ₀
----------------	----------------	----------------	----------------	----------------	----------------	----------------	----------------

Velocity

Data in bytes B₇ - B₆ is the change in the CMC (current measurement count) over a 100 msec time period. This data can then be used to calculate velocity in a post processing operation.

B ₇ - B ₆	HEX (Decimal)	Velocity
0x0000 (0)	0x0000 (0)	- 32767 counts
0x7FFF (32767)	0x7FFF (32767)	"0" counts (no change)
0xFFFF (65535)	0xFFFF (65535)	32767 counts

Velocity Calculation

$$\left(\frac{\text{count change} - 32767}{.1 \text{ sec. time period}} \right) \times \left(\frac{\text{full stroke range}}{65,535} \right)$$

Sample Calculations

Cable Extension (positive direction):

B₇-B₆ = 0x80C6 (32966 Dec), full stroke = 200 in.

$$\left(\frac{32966 - 32767}{.1 \text{ sec}} \right) \times \left(\frac{200 \text{ in.}}{65,535} \right) = 6.07 \text{ in. / sec.}$$

Cable Retraction (negative direction):

B₇-B₆ = 0x7F1A (32538 Dec), full stroke = 200 in.

$$\left(\frac{32538 - 32767}{.1 \text{ sec}} \right) \times \left(\frac{200 \text{ in.}}{65,535} \right) = -6.99 \text{ in. / sec.}$$

Setting the Address (Node ID) and Baud Rate

Address Setting (Node ID)

The Address Setting (Node ID) is set via 6 switches located on the 8-pole DIP switch found on the DeviceNET controller board located inside the transducer.

The DIP switch settings are binary starting with switch number 1 (= 2⁰) and ending with switch number 6 (= 2⁵).

Baud Rate

The transmission baud rate may be either factory preset at the time of order or set manually at the time of installation.

The baud rate can be set using switches 7 & 8 on the 8-pole DIP switch found on the DeviceNET controller board located inside the transducer.

DIP-1 (2 ⁰)	DIP-2 (2 ¹)	DIP-3 (2 ²)	DIP-4 (2 ³)	DIP-5 (2 ⁴)	DIP-6 (2 ⁵)	address (decimal)
0	0	0	0	0	0	0
1	0	0	0	0	0	1
0	1	0	0	0	0	2
...
1	1	1	1	1	1	63

DIP-7	DIP-8	baud rate
0	0	125k
1	0	250k
0	1	500k
1	1	125k



CANBus Controller Board

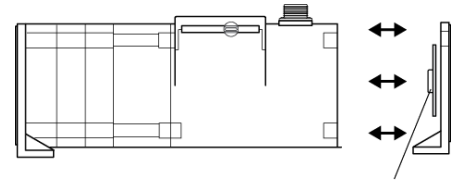

internal dip switches & controller board
to gain access to the controller board, remove four Allen-Head Screws and remove end cover bracket.

Outline Drawing

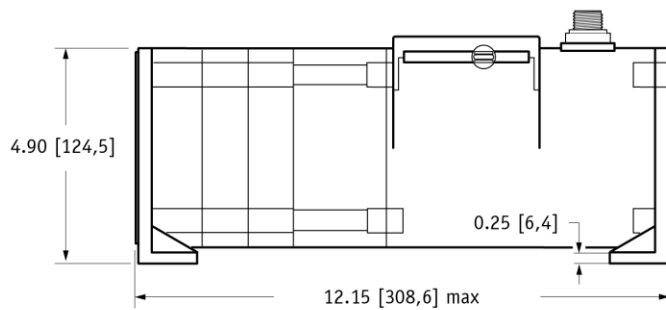
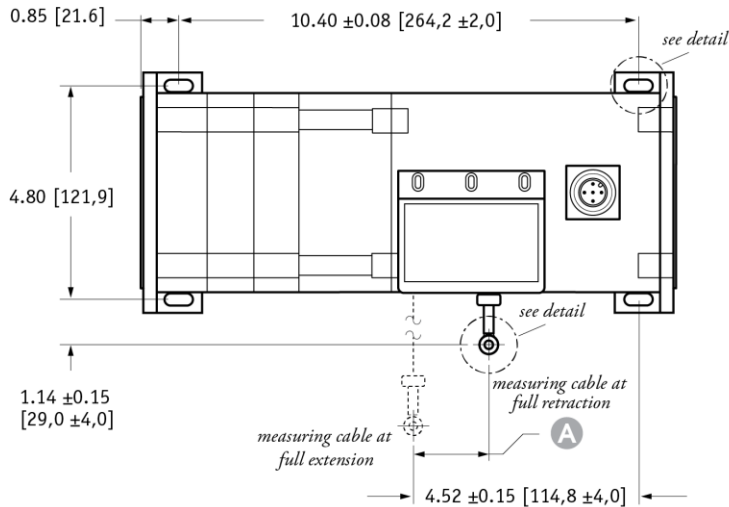

mounting hole detail

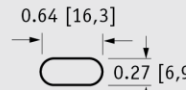

eyelet detail

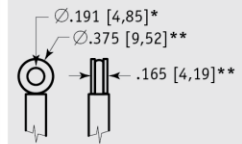

A DIMENSION

RANGE	inches [mm]
600	1.76 [44,7]
800	1.58 [40,1]
1000	1.98 [50,2]
1200	1.98 [50,2]
1500	1.86 [47,2]
1700	2.11 [53,6]

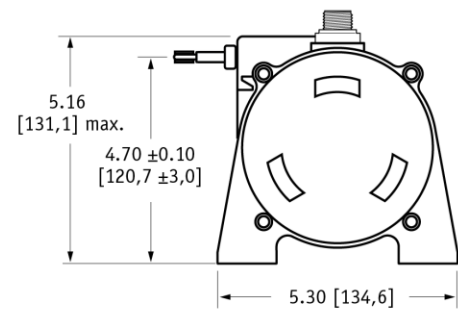

DIMENSIONS ARE IN INCHES [MM]
tolerances are 0.03 IN. [0.5 MM] unless otherwise noted.

* tolerance = +.005 -.001 [+.13 -.03]
** tolerance = +.005 -.005 [+1.13 -.13]

PT9CN

Heavy Industrial • J1939 CANbus • Extended Range

Ordering Information

Model Number:

PT9CN - - **J**

order code: **R** **A** **B** **C** **D** **E** **F**

Sample Model Number:

PT9CN - 1200ALFR - J50032SC5

- R** range: 1200 (1200 inches)
- A** enclosure: AL (aluminum)
- B** cable exit: FR (front)
- C** interface: J (CANbus SAE J1939)
- D** baud rate: 500 (500k bits/sec.)
- E** node ID: 32 (32 decimal)
- F** electrical connection: SC5 (5-meter cordset with straight plug)

Full Stroke Range:

R order code:	600	800	1000	1200	1500	1700
full stroke range, min:	600 in.	800 in.	1000 in.	1200 in.	1500 in.	1700 in.
cable tension (±35%):	27 oz.	24 oz.	20 oz.	19 oz.	18 oz.	17 oz.
measuring cable:	.034-in. dia. nylon-coated stainless	.019-in. dia. nylon-coated stainless	.019-in. dia. nylon-coated stainless	.019-in. dia. nylon-coated stainless	.014-in. dia. nylon-coated stainless	.014-in. dia. nylon-coated stainless

Enclosure Material:

A order code:	AL	SS
enclosure material:	powder-painted aluminum	303 stainless steel
max. acceleration:	1g	1g
max. velocity:	60 inches/sec.	60 inches/sec.

Cable Exit:

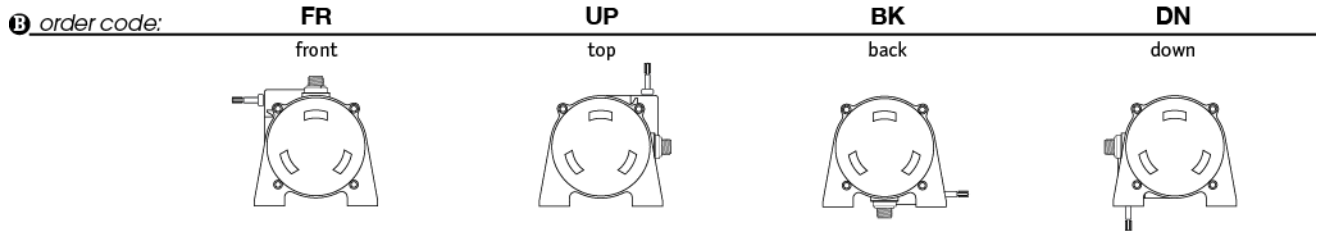

Baud Rate:

D order code:	125	250	500
	125 kbaud	250 kbaud	500 kbaud

Node ID:

E order code:	0	1	2	3	...	61	62	63
	select address (0 - 63 Decimal)							

PT9CN

Heavy Industrial • J1939 CANbus • Extended Range

Electrical Connection:

order code:

blank

5-pin micro-connector
(no mating plug supplied)

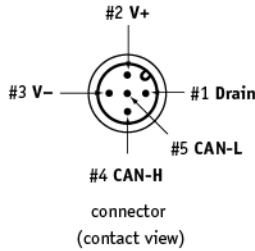

MC5

5-pin micro-connector
w/ mating plug



0.16" - 0.32" OD Cable (THIN)

SC5

5-pin micro-connector
and 5 meter length cordset
w/straight mating plug



length: 16ft [5M]
cable: Thin

NC5

5-pin micro-connector
and 5 meter length cordset
w/90° mating plug

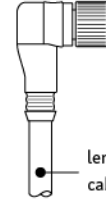

length: 16ft [5M]
cable: Thin

mating plug
(contact view)

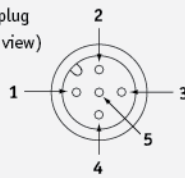

pin	signal	wire color
1	drain	brown
2	V+	white
3	V-	blue
4	Can-H	black
5	Can-L	grey